

Top Section 48" x 72" x 10"

Weight : 3335 Lbs.

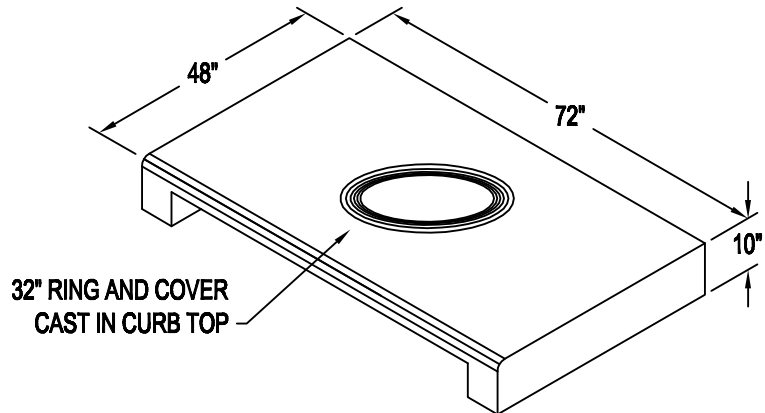

Riser 36" x 60" x 6"

Weight : 675 Lbs.

Riser 36" x 60" x 12"

Weight : 1350 Lbs.

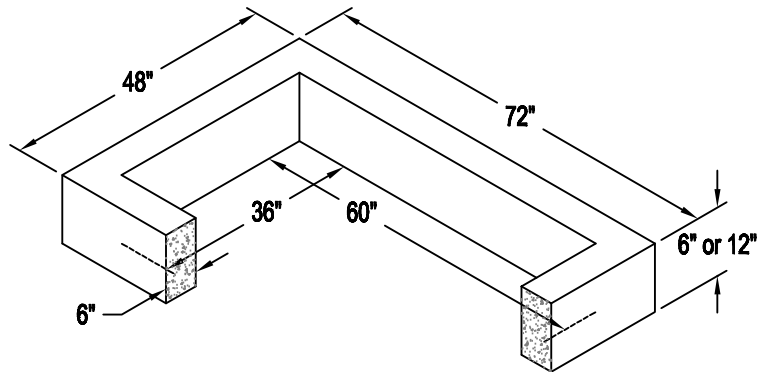

Bottom 36" x 60" x Variable

Weight : (36") 5850 Lbs.

Weight : (48") 7200 Lbs.

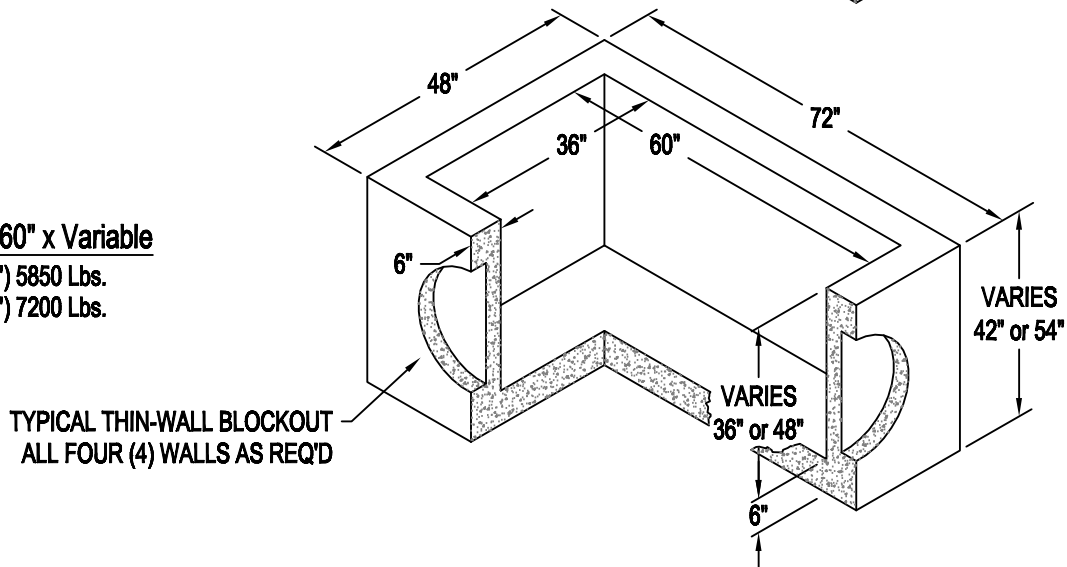

TYPICAL THIN-WALL BLOCKOUT
ALL FOUR (4) WALLS AS REQ'D

SPECIFICATIONS

REINFORCEMENT: GRADE 60 NO. 4 STEEL REBAR TO CONFORM TO ASTM A-615 ON REQ'D CENTERS. GRADE 60.

CONCRETE: CONCRETE DESIGN TO BE CLASS 1 WITH 28 DAY STRENGTH OF 4500 PSI. BOTTOMS TO BE OF MONOLITHIC CONSTRUCTION AS SHOWN.

CASTINGS: RINGS AND COVERS ARE GREY CAST IRON CONFORMING TO ASTM A48-76 CLASS 35

PRECAST OF HOUSTON

"WE DELIVER WHAT OTHER PEOPLE PROMISE"

PHONE : (281) 367-1456
FAX : (281) 419-7860

11393 SLEEPY HOLLOW RD.
CONROE, TX 77385

SCALE : ****
DATE :08/03

APPROVED BY :

DRAWN BY :
RON

36" x 60" TYPE "C" INLET

DRAWING NUMBER :
InTyC

REV. :
0