

**Top Section 48" x 90" x 12"**

Weight : 4500 Lbs.

GRATE 3" x 1/2" PLATE ON 2 1/2" CENTERS (12 SPACES) NOTE: (1) SPACE TO BE AT 2" O.C.

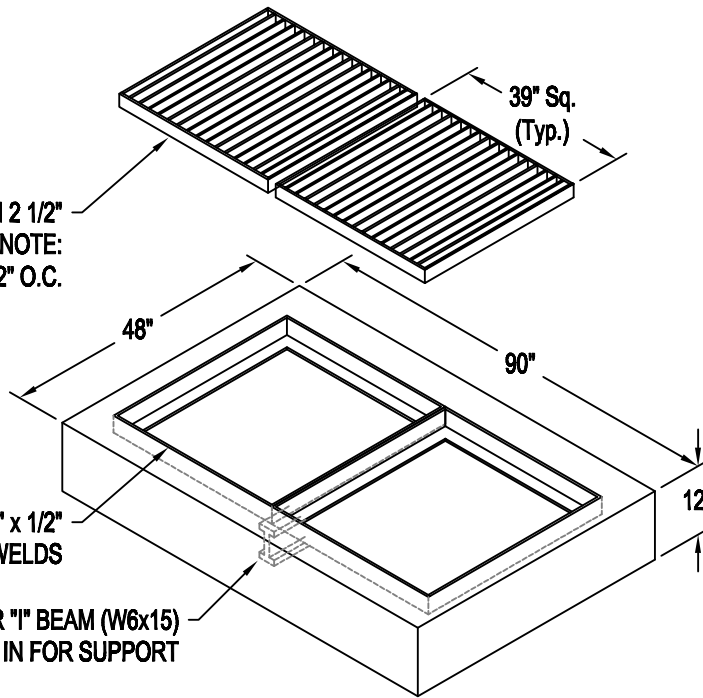

FRAME 3 1/2" x 2 1/2" x 1/2" ANGLE w/ 1/4" x 3" WELDS

CENTER 1" BEAM (W6x15) CAST IN FOR SUPPORT

**Riser 36" x 78" x 6"**

Weight : 790 Lbs.

**Riser 36" x 78" x 12"**

Weight : 1575 Lbs.

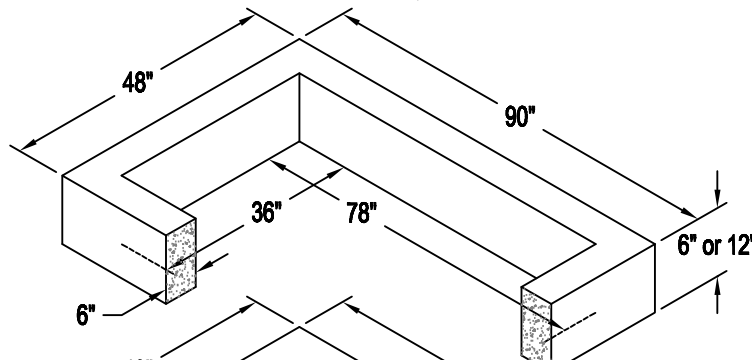

**Bottom 36" x 78" x Variable**

Weight : (36") 6975 Lbs.

Weight : (48") 8550 Lbs.

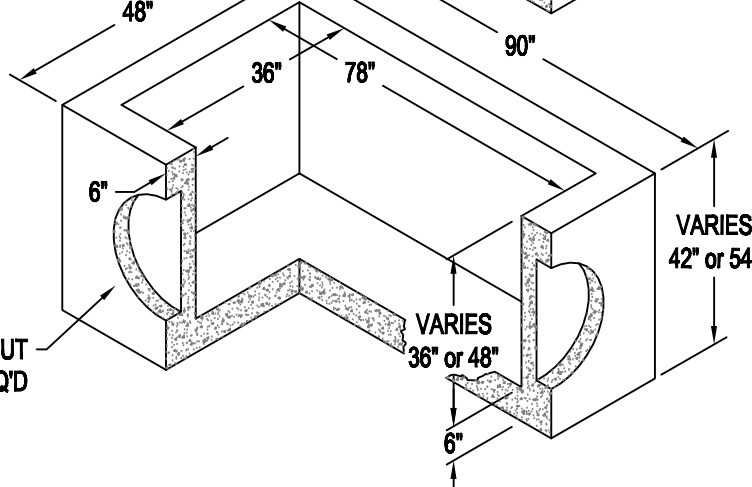

TYPICAL THIN-WALL BLOCKOUT ALL FOUR (4) WALLS AS REQ'D

**SPECIFICATIONS**

REINFORCEMENT: GRADE 60 NO. 4 STEEL REBAR TO CONFORM TO ASTM A-615 ON REQ'D CENTERS. GRADE 60.

CONCRETE: CONCRETE DESIGN TO BE CLASS 1 WITH 28 DAY STRENGTH OF 4500 PSI. BOTTOMS TO BE OF MONOLITHIC CONSTRUCTION AS SHOWN.

CASTINGS: FRAME AND GRATES CAST INTO RISERS AND/OR BOTTOMS TO BE AS SHOWN IN PLANS AND SPECS

**PRECAST OF HOUSTON**

"WE DELIVER WHAT OTHER PEOPLE PROMISE"

PHONE : (281) 367-1456  
FAX : (281) 419-7860

11393 SLEEPY HOLLOW RD.  
CONROE, TX 77385

SCALE : \*\*\*\*  
DATE : 08/03

APPROVED BY :

DRAWN BY :  
RON

**36" x 78" TYPE "CC" INLET**

DRAWING NUMBER : InTyCC-Valley

REV. :  
0